



avantium

A CERIM AND ATOM COMPANY

Shoes machinery  
and automated systems



ATOM



MADE IN ITALY

# K58TX

## Montaboette a tracciatori



La K58TX nasce come naturale evoluzione della storica macchina K58STI. Il sistema di spalmatura di collante termoplastico direttamente sul sottopiede avviene tramite tracciatori.

Grazie all'utilizzo del controllo elettronico completo della macchina vengono inoltre memorizzate tutte le funzioni ciclo, i tempi, i dati di incollaggio per l'intera numerata.

Conforme ai requisiti Industria 4.0

### SETTORI DI APPLICAZIONE



Uomo



Donna



Bambino



Safety



Sportive



Sneakers Montato

# CARATTERISTICHE K58TX



Spalmatura del collante termoplastico direttamente sul sottopiede



Sistema di programmazione con Touch Screen 7" con archivio programmi su chiavetta USB, funzioni di autodiagnostica



[VAI ALLA SCHEDA TECNICA >](#)

# K58TX

## Tracers heel seat lasting machine



The K58TX born on the natural evolution of the well known K58STI. The cement is applied by tracers directly on the insole.

Thanks to the full electronic control of the machine, all cycles settings, timers, cementing data for all sizes.

- Industria 4.0 ready

### SECTORS OF APPLICATION



Man



Woman



Child



Safety



Sports



Lasted Sneakers



# FEATURES K58TX



Thermocement application by tracers directly on the insole



7" Touch screen programming system with styles storage on USB key, autodiagnostic functions



[VIEW DATASHEET >](#)

# SCHEDA TECNICA K58TX

DIMENSIONI (L x P x H)	mm 900 x 1300 x 1900
DIMENSIONI IMBALLO	mm 1100 x 1550 x 2130
PESO NETTO	Kg 640
PESO LORDO IN CASSA	Kg 780
POTENZA ELETTRICA TOTALE INSTALLATA	Kw 3,7
ALIMENTAZIONE PNEUMATICA	Bar 6
ALIMENTAZIONE ELETTRICA	3PH + PE

[< TORNA AI DETTAGLI DELLA MACCHINA](#)

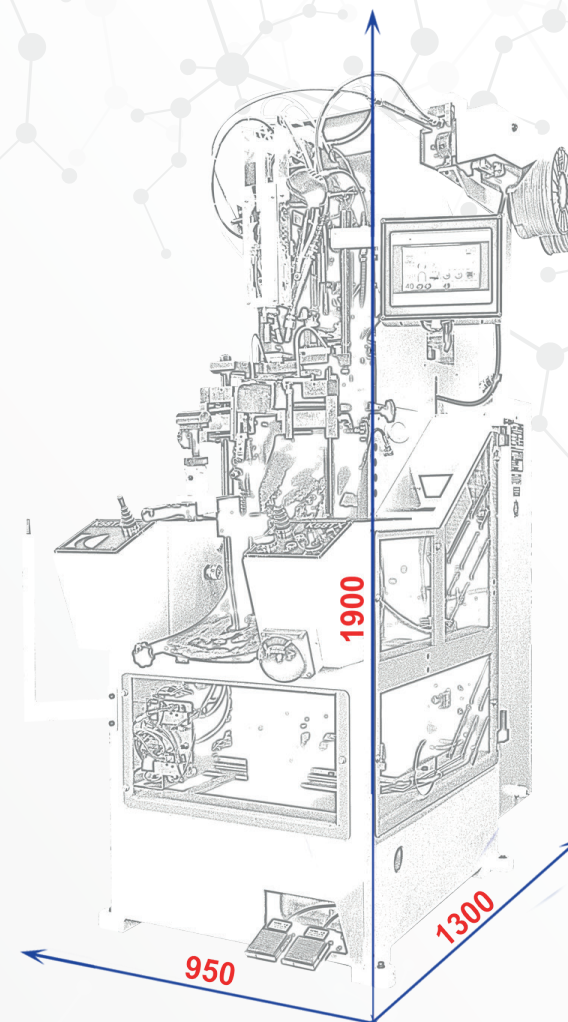

# TECHNICAL FEATURES K58TX

DIMENSIONS (L x W x H)	mm 900 x 1300 x 1900
PACKAGING DIMENSIONS	mm 1100 x 1550 x 2130
NET WEIGHT	Kg 640
GROSS WEIGHT IN CASE	Kg 780
TOTAL INSTALLED ELECTRIC POWER	Kw 3,7
PNEUMATIC POWER SUPPLY	Bar 6
POWER SUPPLY	3PH + PE

[< BACK TO THE MACHINE DETAILS](#)

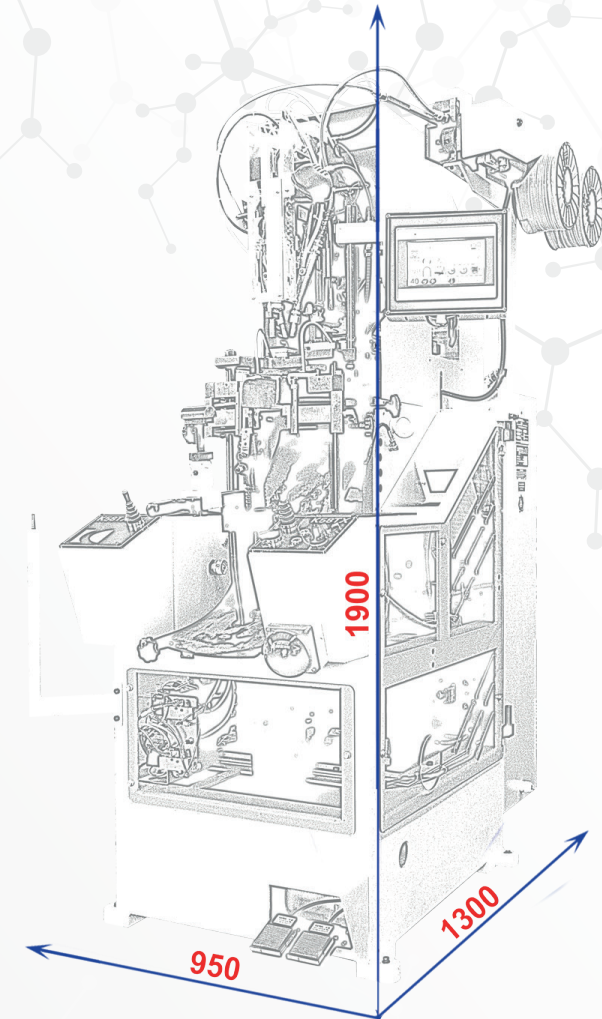



**avantium**

A CERIM AND ATOM COMPANY

**Avantium**

Corso Novara, 218  
27029 Vigevano (PV) - Italia

Tel: +39 0381 20905

[www.avantium.it](http://www.avantium.it)

Email: [info@avantium.it](mailto:info@avantium.it)



ATOM



MADE IN ITALY