



avantium

A CERIM AND ATOM COMPANY

Shoes machinery
and automated systems



ATOM



MADE IN ITALY



Macchina per l'incollaggio laterale della calzatura.

- Sei assi programmabili
- Incollaggio a pennello
- Sistema di programmazione con display touch screen
- Espansione automatica della numerata
- Lavorazione con differenti pressioni e velocità per punto programmato
- Correzioni istantanee e indipendenti per zona, scarpa destra e/o sinistra, numero.
- Adatta sia a collanti ad acqua che a solvente
- Conforme ai requisiti Industria 4.0

SETTORI DI APPLICAZIONE



Uomo



Donna



Bambino



Safety



Sportive



Sneakers Montato



Sneakers Strobel

CARATTERISTICHE K195



Nuovo digitalizzatore DGT,
possibilità di creare i programmi
direttamente in macchina in
maniera semplice e veloce.

[VAI ALLA SCHEDA TECNICA >](#)

Automatic upper side cementing machine

- Six programmable axis
- Cementing by brush
- Programming system with touch screen display
- Automatic sizes expansion
- Working with different pressures and speed for programmed point.
- Instant and independent corrections for zone, right and/or left shoe, size
- Suitable for solvent or water based glues
- Industria 4.0 ready



SECTORS OF APPLICATION



Man



Woman



Child



Safety



Sports



Lasted Sneakers



Sneakers Strobel

FEATURES K195



DGT digitizer, programs can be created directly in the machine quickly and easily.

[VIEW DATASHEET >](#)

SCHEDA TECNICA K195

DIMENSIONI (L x P x H)	mm 1550 x 2200 x 2250
DIMENSIONI IMBALLO	mm 1900 x 2500 x 2240
PESO NETTO	Kg 960
PESO LORDO IN CASSA	Kg 1120
POTENZA ELETTRICA TOTALE INSTALLATA	Kw 6,0
ALIMENTAZIONE PNEUMATICA	Bar 6
ALIMENTAZIONE ELETTRICA	3PH + N + PE

[< TORNA AI DETTAGLI DELLA MACCHINA](#)

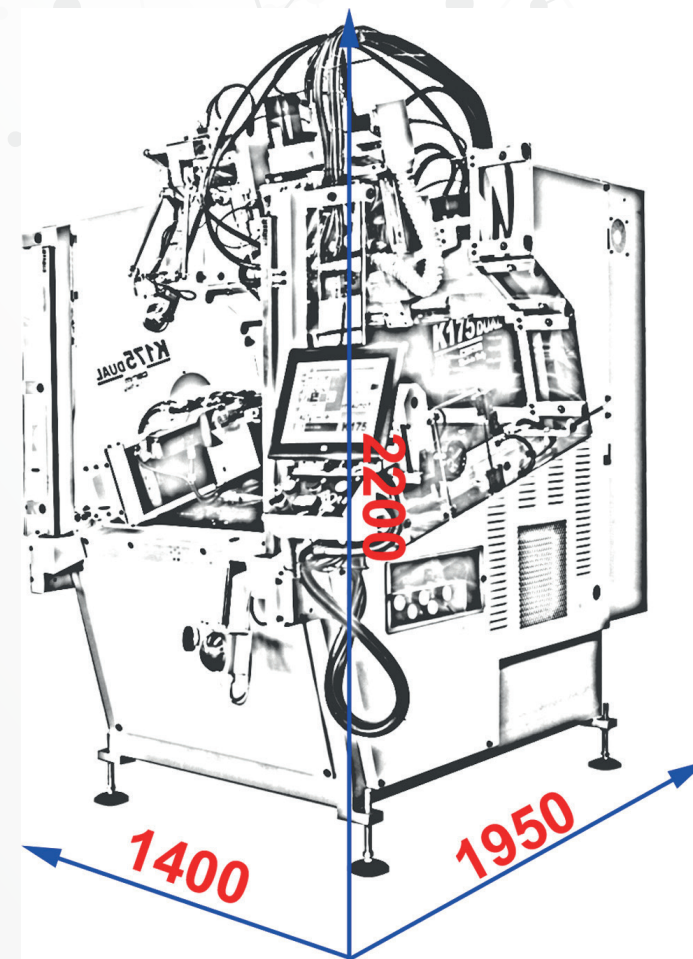

TECHNICAL FEATURES K195

DIMENSIONS (L x W x H)	mm 1550 x 2200 x 2250
PACKAGING DIMENSIONS	mm 1900 x 2500 x 2240
NET WEIGHT	Kg 960
GROSS WEIGHT IN CASE	Kg 1120
TOTAL INSTALLED ELECTRIC POWER	Kw 6,0
PNEUMATIC POWER SUPPLY	Bar 6
POWER SUPPLY	3PH + N + PE

[< BACK TO THE MACHINE DETAILS](#)

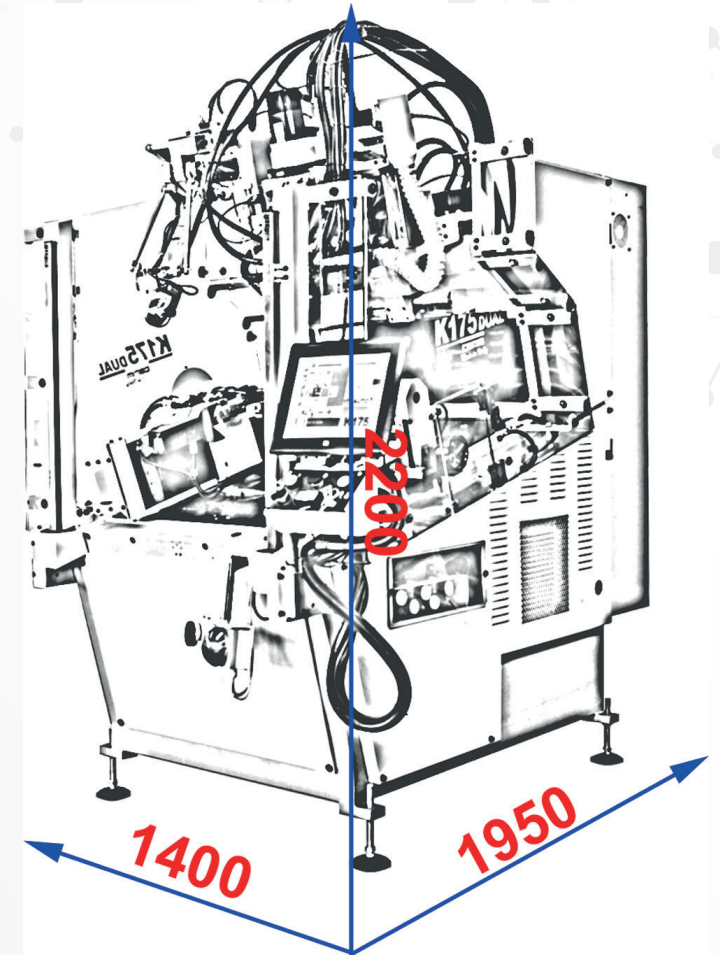



avantium

A CERIM AND ATOM COMPANY

Avantium

Corso Novara, 218
27029 Vigevano (PV) - Italia

Tel: +39 0381 20905

www.avantium.it

Email: info@avantium.it



ATOM



MADE IN ITALY