



avantium

A CERIM AND ATOM COMPANY

Shoes machinery
and automated systems



ATOM



MADE IN ITALY



I nuovi cinematismi e la rotazione utensile con motori brushless a potenza elevata, uniti al controllo accurato dei giri motore, assicurano costanza nella lavorazione dei pellami dai più delicati ai più resistenti.

- Sei assi programmabili.
- Altissima definizione del profilo di lavoro.
- Sistema di programmazione con display touch screen.
- Espansione automatica della numerata.
- Lavorazione con differenti pressioni e velocità per punto programmato.
- Correzioni istantanee e indipendenti per zona, scarpa destra e / o sinistra, numero.
- Nuovo digitalizzatore DGT, possibilità di creare i programmi direttamente in macchina in maniera semplice e veloce.
- Nuovo sgancio rapido conico dell'utensile, ispirato al sistema ISO SK, consente una facilità di manutenzione e sostituzione unica nel settore.
- Altissima produttività.
- Autodiagnostica.
- Conforme ai requisiti Industria 4.0

SETTORI DI APPLICAZIONE



Uomo



Donna



Bambino



Safety



Sportive



Sneakers Montato



Sneakers Strobel

CARATTERISTICHE K175



Nuovo digitalizzatore DGT,
possibilità di creare i programmi
direttamente in macchina in
maniera semplice e veloce.

[VAI ALLA SCHEDA TECNICA >](#)

K175

Automatic side roughing machine



The new kinematic mechanisms and the rotation of the tool with high power brushless motors, together with the accurate control of the engine revolutions, ensure constancy in the processing of leathers from the most delicate to the most resistant.

- Six programmable axis.
- Extreme accuracy of the working path.
- Display touch screen programming system.
- Automatic expansion for all sizes.
- Working operation allowing different pressures and speed at any programmed point.
- Instantaneous and independent programming and correction for zone, right and / or left shoe, size.
- DGT digitizer, programs can be created directly in the machine quickly and easily.
- New conical quick release of the tool, inspired by the ISO SK system, allows an easy maintenance and replacement unique in the sector.
- Very high output
- Self diagnostics
- Industria 4.0 ready

SECTORS OF APPLICATION



Man



Woman



Child



Safety



Sports



Lasted Sneakers



Sneakers Strobel

FEATURES K175



DGT digitizer, programs can be created directly in the machine quickly and easily.

[VIEW DATASHEET >](#)

SCHEDA TECNICA K175

DIMENSIONI (L x P x H)	mm 1550 x 2200 x 2250
DIMENSIONI IMBALLO	mm 1900 x 2500 x 2240
PESO NETTO	Kg 960
PESO LORDO IN CASSA	Kg 1120
POTENZA ELETTRICA TOTALE INSTALLATA	Kw 6,0
ALIMENTAZIONE PNEUMATICA	Bar 6
ALIMENTAZIONE ELETTRICA	3PH + N + PE

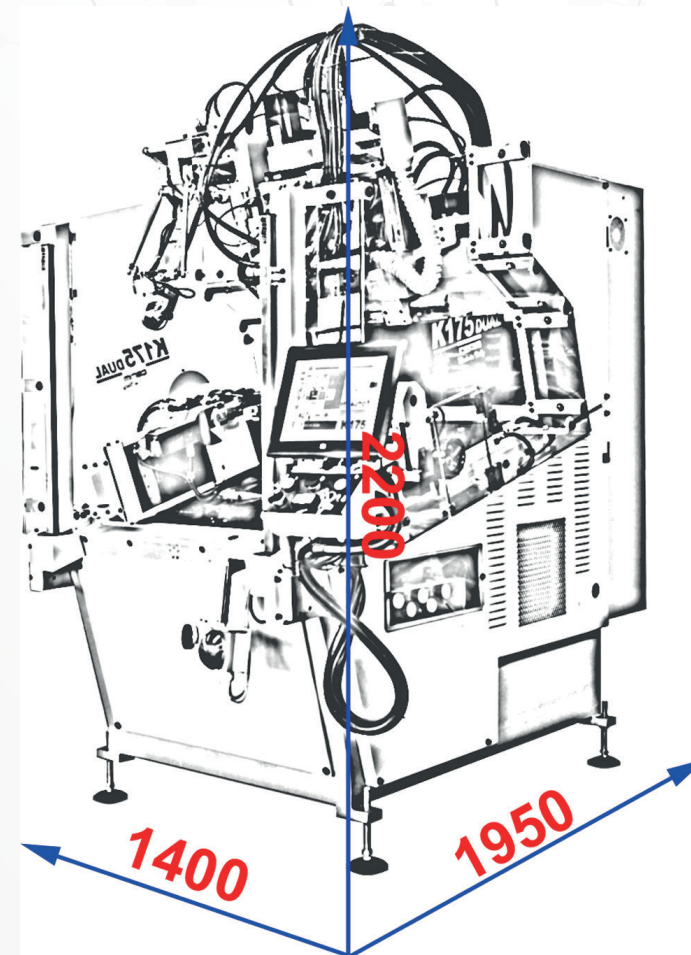

[< TORNA AI DETTAGLI DELLA MACCHINA](#)

TECHNICAL FEATURES K175

DIMENSIONS (L x W x H)	mm 1550 x 2200 x 2250
PACKAGING DIMENSIONS	mm 1900 x 2500 x 2240
NET WEIGHT	Kg 960
GROSS WEIGHT IN CASE	Kg 1120
TOTAL INSTALLED ELECTRIC POWER	Kw 6,0
PNEUMATIC POWER SUPPLY	Bar 6
POWER SUPPLY	3PH + N + PE

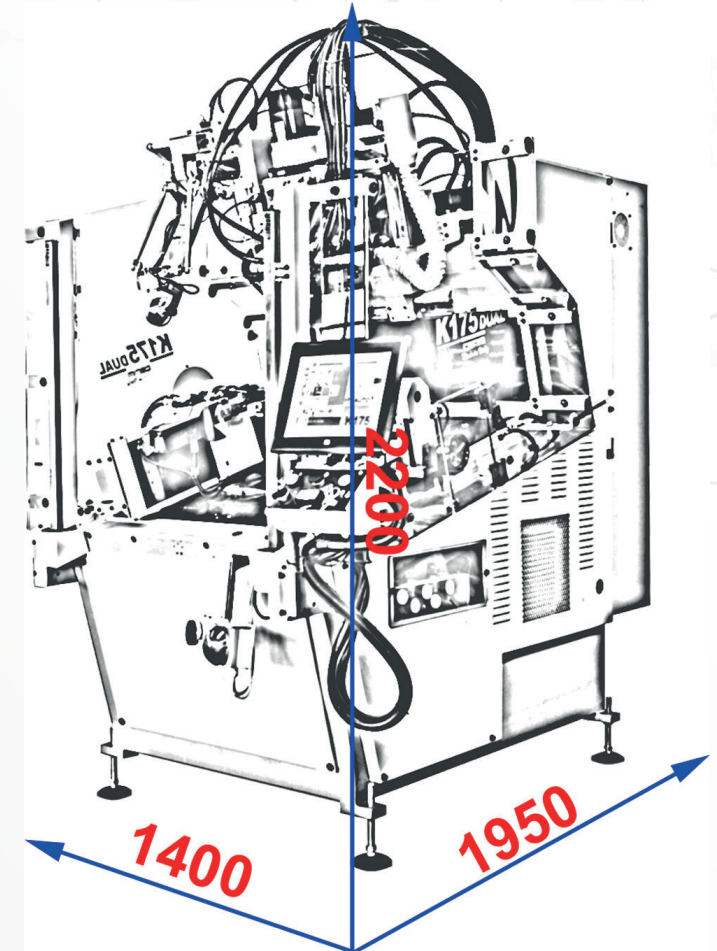

< BACK TO THE MACHINE DETAILS



avantium
A CERIM AND ATOM COMPANY

Avantium

Corso Novara, 218
27029 Vigevano (PV) - Italia
Tel: +39 0381 20905
www.avantium.it
Email: info@avantium.it



ATOM



MADE IN ITALY