



avantium

A CERIM AND ATOM COMPANY

Shoes machinery  
and automated systems



ATOM



MADE IN ITALY

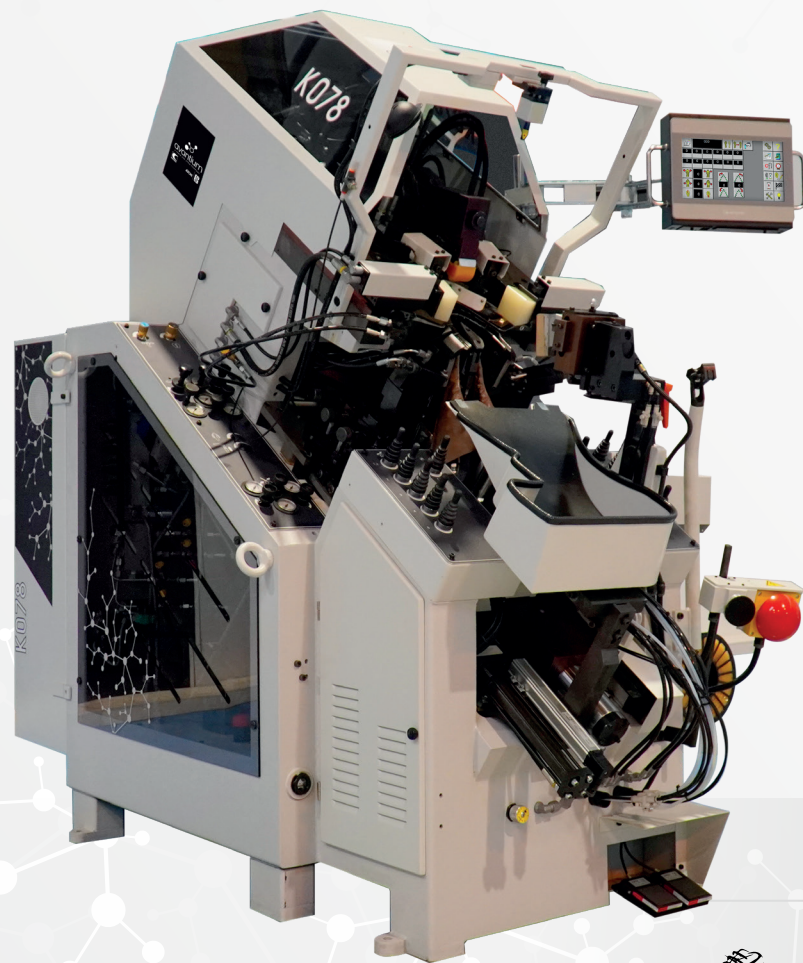

## PROGRAMMABILITÀ PER:

- Tempi, funzioni, tiraggi e traguardi di apertura pinze.
- Tracciatori per la totale distribuzione del collante.
- Accerchiamento pinze per il profilo forma, corsa piastre, supporto forma con posizioni intermedie e pressore posteriore.
- Testa mobile programmabile
- Conforme ai requisiti Industria 4.0

## SETTORI DI APPLICAZIONE



Uomo



Donna



Bambino



Safety



Sportive



Sneakers Montato



Goodyear

# CARATTERISTICHE: K078



Meno di 2 minuti per il cambio di forma nella lavorazione.



Due tracciatori mobili per la totale distribuzione del collante termoplastico su qualsiasi tipo di scarpa ed in qualsiasi misura



Display touch screen da 10" a colori multilingua con funzioni di autodiagnostica.



Doppio piedino di sostegno per punte sfilate.



Nuovo gruppo pinze **MULTI SHAPE**: massima precisione di accerchiamento; sostituzione ad innesto rapido delle 3 pinze di punta.

## OPTIONAL E ACCESSORI

- Gruppo pinze **MULTI SHAPE**
- Sistema **CALIBRATORE MERCALLI**.
- Tiraggio orizzontale pinze 5.
- Inclinazione piattello programmabile.
- Lavorazione per scarpe "goodyear" e scarpe "safety" (puntale in ferro).
- Doppio piedino di sostegno per punte sfilate
- **EASY LINK**

[VAI ALLA SCHEDA TECNICA >](#)

# K078

## Pullingover, toe and forepart lasting machine, electronic and hydraulic

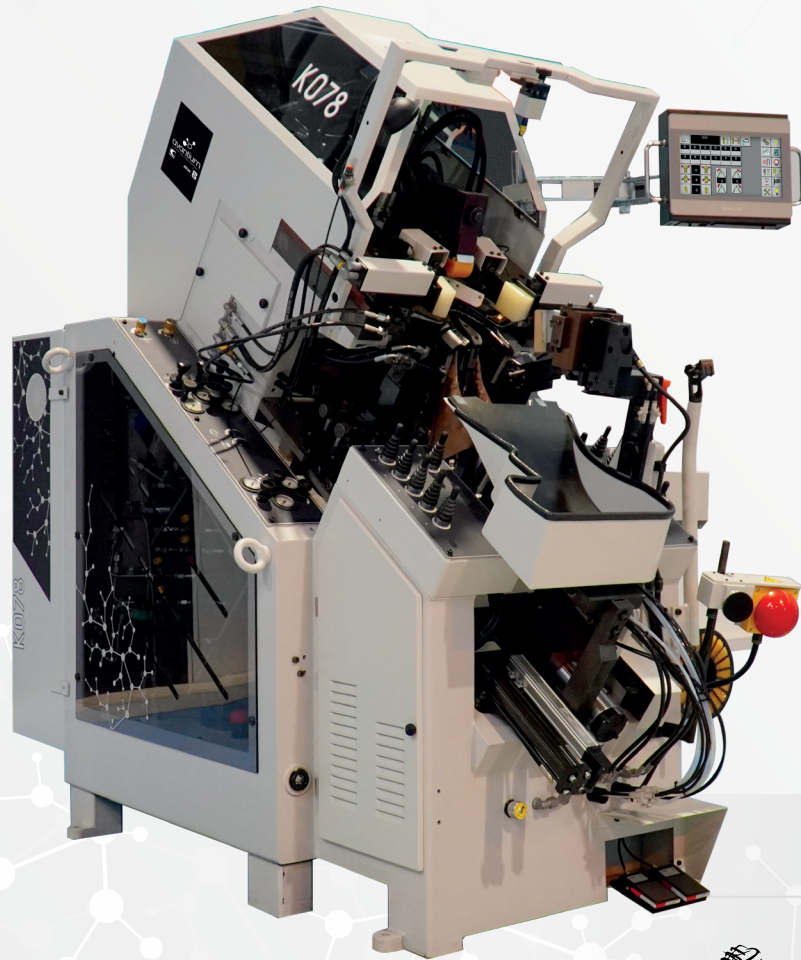

### Programmability for:

- Opening pincers times, functions, pincer's draftings and goals.
- Tracers for the whole cement distribution.
- Pincers encirclement for last profile, wipers stroke, last support with intermediate positions and heel rest.
- Programmable movable head
- Industria 4.0 ready

### SECTORS OF APPLICATION



Man



Woman



Child



Safety



Sports



Lasted Sneakers



Goodyear



# FEATURES: K078



Less than 2 minutes for change of style.



Total thermocement application by two movable tracers suitable for any kind of shoe in any size



Full color multilanguage 10" touch screen display with fault assistant.



Double last support for pointed toes.



New **MULTI SHAPE** programmed pincers unit: extreme accuracy of pincers encirclement. Quick toe pincers changing system.

## OPTIONALS & ACCESSORIES

- **MULTI SHAPE** pincers group
- **Mercalli Calibrator System.**
- Pincers n. 5 horizontal drafting.
- Programmable last support inclination.
- Units for good year shoes and for safety shoes (steel toe cap).
- Double last support for pointed toes.
- **EASY LINK**

[VIEW DATASHEET >](#)

# SCHEDA TECNICA K078

DIMENSIONI (L x P x H)	mm 1220 x 1900 x 1950
DIMENSIONI IMBALLO	mm 1300 x 2100 x 2260
PESO NETTO	Kg 1300
PESO LORDO IN CASSA	Kg 1520
POTENZA ELETTRICA TOTALE INSTALLATA	Kw 5,5
ALIMENTAZIONE PNEUMATICA	Bar 6
ALIMENTAZIONE ELETTRICA	3PH + PE

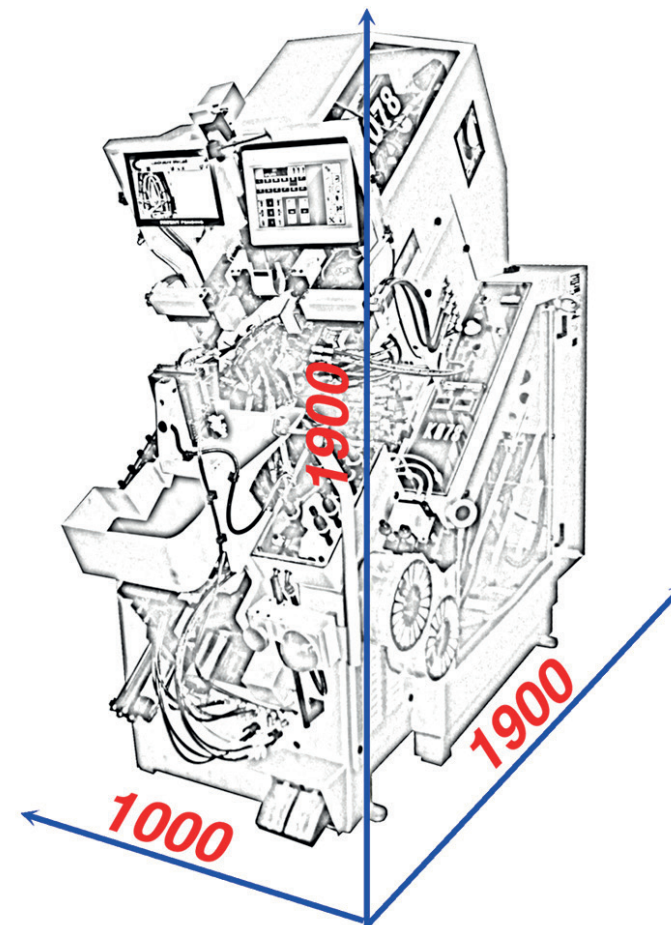

< TORNA AI DETTAGLI DELLA MACCHINA

# TECHNICAL FEATURES K078

DIMENSIONS (L x W x H)	mm 1220 x 1900 x 1950
PACKAGING DIMENSIONS	mm 1300 x 2100 x 2260
NET WEIGHT	Kg 1300
GROSS WEIGHT IN CASE	Kg 1520
TOTAL INSTALLED ELECTRIC POWER	Kw 5,5
PNEUMATIC POWER SUPPLY	Bar 6
POWER SUPPLY	3PH + PE

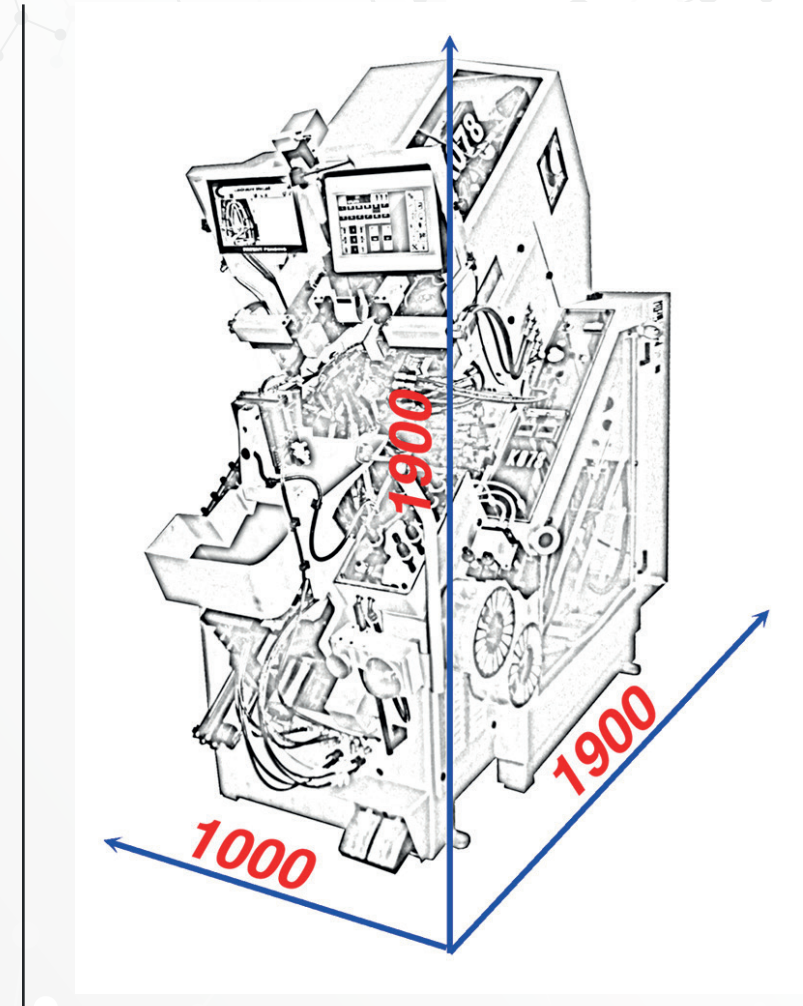

[< BACK TO THE MACHINE DETAILS](#)



**avantium**  
A CERIM AND ATOM COMPANY

**Avantium**

Corso Novara, 218  
27029 Vigevano (PV) - Italia  
Tel: +39 0381 20905  
[www.avantium.it](http://www.avantium.it)  
Email: [info@avantium.it](mailto:info@avantium.it)



ATOM



MADE IN ITALY