



avantium

A CERIM AND ATOM COMPANY

Shoes machinery
and automated systems



ATOM



MADE IN ITALY

CD3 TS2/CC

Macchina per incollare il fondo della scarpa



Con 2 teste indipendenti che consentono di applicare 2 tipi di colla diversa (es. primer+colla) sulla stessa calzatura, oppure la stessa colla per lavorazioni di alta produttività.

- Monitor touch screen da 15", in posizione ergonomica
- Sistema operativo MS Windows
- Sistema di salvataggio e aggiornamento dei dati con supporto USB
- Reale possibilità di assistenza remota
- Programmazione dell'utensile di incollaggio che segue il percorso tridimensionale
- Velocità di rotazione del pennello programmabile punto a punto
- Fotocellule per sbloccare la forma, senza intervento manuale
- Autoapprendimento del profilo della scarpa con sviluppo automatico della numerata
- Adatta sia per colle ad acqua che a solvente
- Assistenza remota mediante TeamViewer
- Conforme ai requisiti Industria 4.0

SETTORI DI APPLICAZIONE



Uomo



Donna



Bambino



Safety



Sportive



Sneakers Montato



Goodyear



Sneakers Strobel

CARATTERISTICHE CD3 TS2/CC

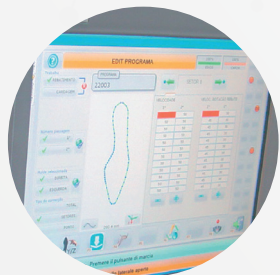

AUTOAPPRENDIMENTO

Autoapprendimento del profilo della calzatura e calcolo automatico dell'inclinazione degli utensili, il tutto comodamente gestito tramite schermo touch screen.



INCOLLAGGIO

Programmazione della velocità di rotazione dell'utensile di incollaggio, ad inseguimento del percorso tridimensionale. Motorizzazione evoluta con software per la lettura dell'encoder.



IMPOSTAZIONI ERGONOMICHE

Touch screen in posizione ergonomica. Sistema operativo evoluto in windows, comunicazione universale; sistemi di salvataggio dati e aggiornamenti tramite supporto usb.

[VAI ALLA SCHEDA TECNICA >](#)

CD3 TS2/CC

Cementing machine for the shoe bottom



With two independent heads to apply two different kind of cement (e.g. primer + cement) on the same shoe, or the same cement for high productivity working.

It presents the following features:

- 15" Touch Screen monitor, in ergonomic position
- MS Windows operative system
- Data saving and updating system by means of USB support
- Real possibility of remote assistance
- Cementing tool adjustment following the three-dimensional path
- Brush speed adjustable point by point
- Photocells to unlock the last, without manual intervention
- Self-learning of the footwear profile with automatic shoe size development
- Suitable both for water- and solvent-based cement
- Remote assistance by TeamViewer
- Industria 4.0 ready

SECTORS OF APPLICATION



Man



Woman



Child



Safety



Sports



Lasted Sneakers



Goodyear



Sneakers Strobel

FEATURES CD3 TS2/CC



SELF-LEARNING

Self-learning of the shoe profile by pen, and automatic calculation of the inclination of the tools, all conveniently managed by touchscreen.



CEMENTING

Speed setting for the rotation of the cementing tool, following the three-dimensional traced path. Motorization updated with software for the encoder reading.



ERGONOMIC SETTINGS

Touch screen in ergonomic position. Windows updated operating system, universal communication; data rescue system and updates by USB support.

[VIEW DATASHEET >](#)

SCHEDA TECNICA CD3 TS2/CC

DIMENSIONI (L x P x H)	mm 1280 x 1850 x 2100
DIMENSIONI IMBALLO	mm 1400 x 2000 x 2240
PESO NETTO	kg 1150
PESO LORDO IN CASSA	kg 1420
POTENZA ELETTRICA TOTALE INSTALLATA	Kw 4,5
ALIMENTAZIONE PNEUMATICA	Bar 6
ALIMENTAZIONE ELETTRICA	3PH + PE

[< TORNA AI DETTAGLI DELLA MACCHINA](#)

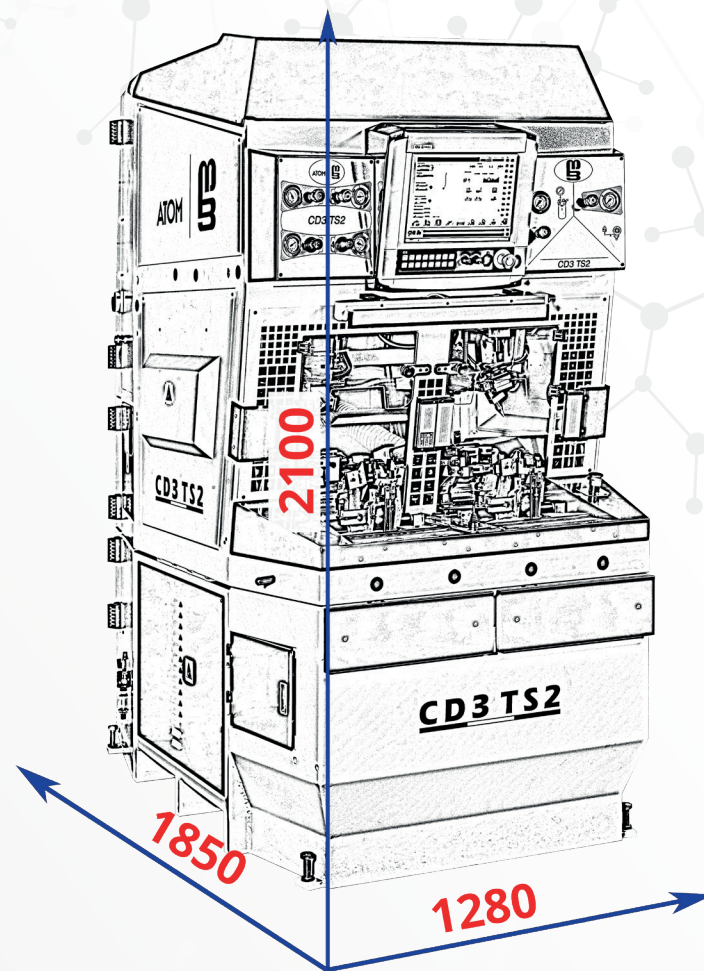

TECHNICAL FEATURES CD3 TS2/CC

DIMENSIONS (L x W x H)	mm 1280 x 1850 x 2100
PACKAGING DIMENSIONS	mm 1400 x 2000 x 2240
NET WEIGHT	kg 1150
GROSS WEIGHT IN CASE	kg 1420
TOTAL INSTALLED ELECTRIC POWER	Kw 4,5
PNEUMATIC POWER SUPPLY	Bar 6
POWER SUPPLY	3PH + PE

< [BACK TO THE MACHINE DETAILS](#)

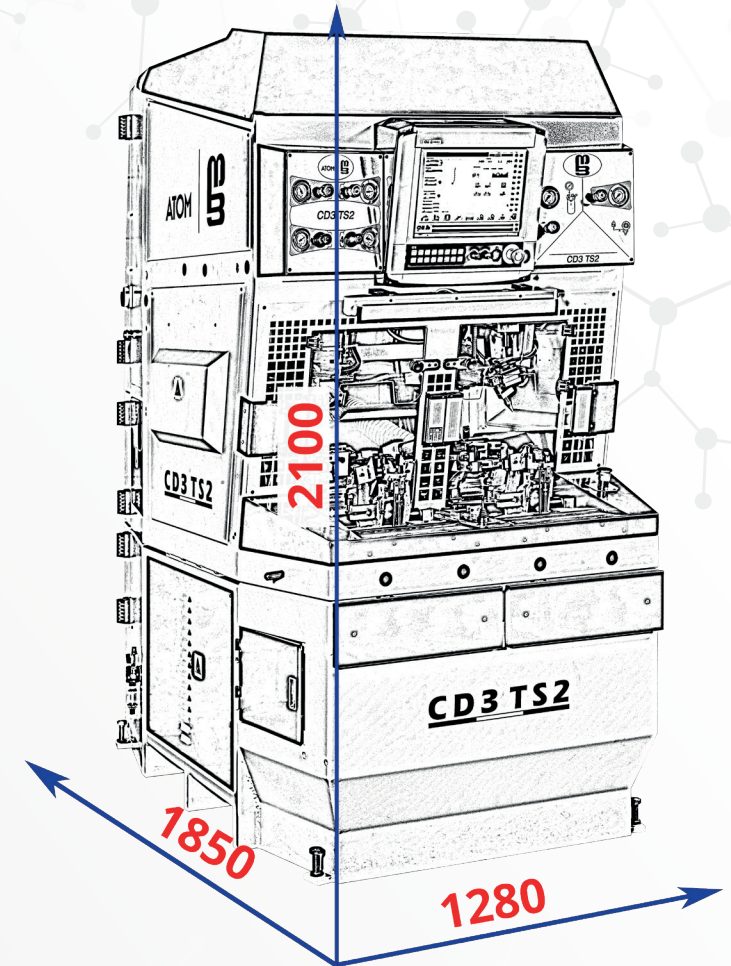



avantium
A CERIM AND ATOM COMPANY

Avantium

Corso Novara, 218
27029 Vigevano (PV) - Italia
Tel: +39 0381 20905
www.avantium.it
Email: info@avantium.it



ATOM



MADE IN ITALY