



avantium

A CERIM AND ATOM COMPANY

Shoes machinery
and automated systems



ATOM



MADE IN ITALY

CD3 TS2/CI

Macchina per incollare/cardare ribattere/incollare il fondo



Con 2 teste indipendenti che lavorano contemporaneamente.

- Monitor touch screen da 15"
- Sistema operativo MS Windows
- Sistema di salvataggio e aggiornamento dei dati con supporto USB
- Reale possibilità di assistenza remota
- Programmazione dell'utensile di incollaggio/cardatura/ribattitura che segue il percorso tridimensionale
- Velocità e pressione degli utensili programmabile punto a punto
- Velocità di rotazione del pennello e programmabile punto a punto
- Fotocellule per sbloccare la forma, senza intervento manuale
- Autoapprendimento del profilo della scarpa con sviluppo automatico della numerata
- Adatta sia per colle ad acqua che a solvente
- Assistenza remota mediante TeamViewer
- Conforme ai requisiti Industria 4.0

SETTORI DI APPLICAZIONE



Uomo



Donna



Bambino



Safety



Sportive



Sneakers Montato



Sneakers Strobel

CARATTERISTICHE CD3 TS2/CI

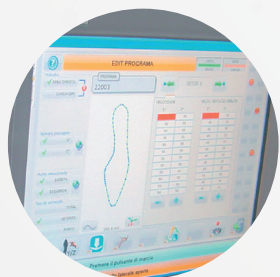

AUTOAPPRENDIMENTO

Autoapprendimento del profilo della calzatura e calcolo automatico dell'inclinazione degli utensili, il tutto comodamente gestito tramite schermo touch screen.



INCOLLAGGIO E CARDATURA

Programmazione della velocità di rotazione della spazzola / utensile di cardatura. Spazzola ad inseguimento del percorso tridimensionale, con possibilità di cambio rapido della spazzola. Sistema per la raccolta polveri interno e motorizzazione evoluta con software per la lettura dell'encoder.



IMPOSTAZIONI ERGONOMICHE

Touch screen in posizione ergonomica. Sistema operativo evoluto in windows, comunicazione universale; sistemi di salvataggio dati e aggiornamenti tramite supporto usb.

OPTIONAL E ACCESSORI

- Smerigliatrice laterale
- Modifica colla (acqua+solvente)
- Utensile ribattitura strobel per la variante lavorazione ribattitura cucitura strobel e incollaggio.

[VAI ALLA SCHEDA TECNICA >](#)

CD3 TS2/CI

Roughing/cementing machine



For the shoe bottom, or pounding/cementing machine (strobel shoes), with two independent heads that carry out the operations simultaneously.

It presents the following features:

- 15" Touch Screen monitor
- MS Windows operative system
- Data saving and updating system by means of USB support
- Real possibility of remote assistance
- Cementing/roughing/pounding tool adjustment following the three-dimensional path
- Speed and pressure of the tools adjustable point by point
- Brush rotation speed adjustable point by point
- Photocells to unlock the last, without manual intervention
- Self-learning of the footwear profile with automatic shoe size development
- Suitable both for water- and solvent-based cement
- Remote assistance by TeamViewer
- Industria 4.0 ready

SECTORS OF APPLICATION



Man



Woman



Child



Safety



Sports



Lasted Sneakers



Sneakers Strobel

FEATURES CD3 TS2/CI



SELF-LEARNING

Self-learning of the shoe profile by pen, and automatic calculation of the inclination of the tools, all conveniently managed by touchscreen.



ROUGHING / CEMENTING

Speed setting for the rotation of the roughing brush/tool. Roughing brush following the three-dimensional traced path, with the possibility of quick brush change. Internal system for dust collection and motorization updated with software for the encoder reading.



ERGONOMIC SETTINGS

Touch screen in ergonomic position. Windows updated operating system, universal communication; data rescue system and updates by USB support.

OPTIONALS & ACCESSORIES

- Roughing tool on the machine side
- Universal cement modification (water+solvent)
- Strobel pounding tool for strobel shoes pounding and cementing

[VIEW DATASHEET >](#)

SCHEDA TECNICA CD3 TS2/CI

DIMENSIONI (L x P x H)	mm 1280 x 1850 x 2100
DIMENSIONI IMBALLO	mm 1400 x 2000 x 2240
PESO NETTO	kg 1150
PESO LORDO IN CASSA	kg 1420
POTENZA ELETTRICA TOTALE INSTALLATA	Kw 6,0
ALIMENTAZIONE PNEUMATICA	Bar 6
ALIMENTAZIONE ELETTRICA	3PH + PE

[< TORNA AI DETTAGLI DELLA MACCHINA](#)

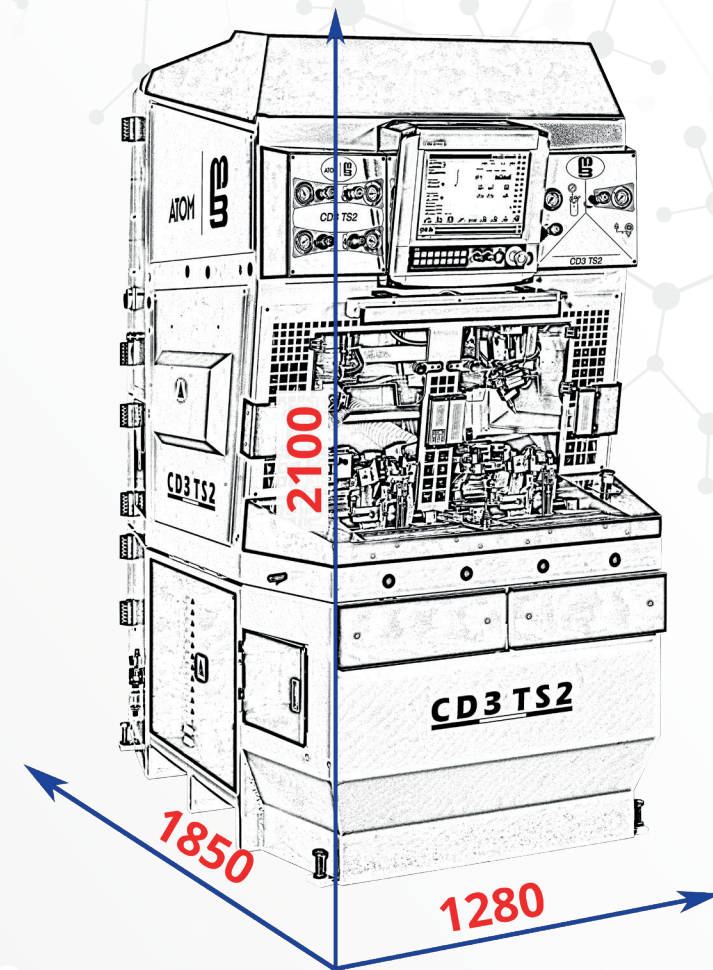

TECHNICAL FEATURES CD3 TS2/CI

DIMENSIONS (L x W x H)	mm 1280 x 1850 x 2100
PACKAGING DIMENSIONS	mm 1400 x 2000 x 2240
NET WEIGHT	kg 1150
GROSS WEIGHT IN CASE	kg 1420
TOTAL INSTALLED ELECTRIC POWER	Kw 6,0
PNEUMATIC POWER SUPPLY	Bar 6
POWER SUPPLY	3PH + PE

< [BACK TO THE MACHINE DETAILS](#)

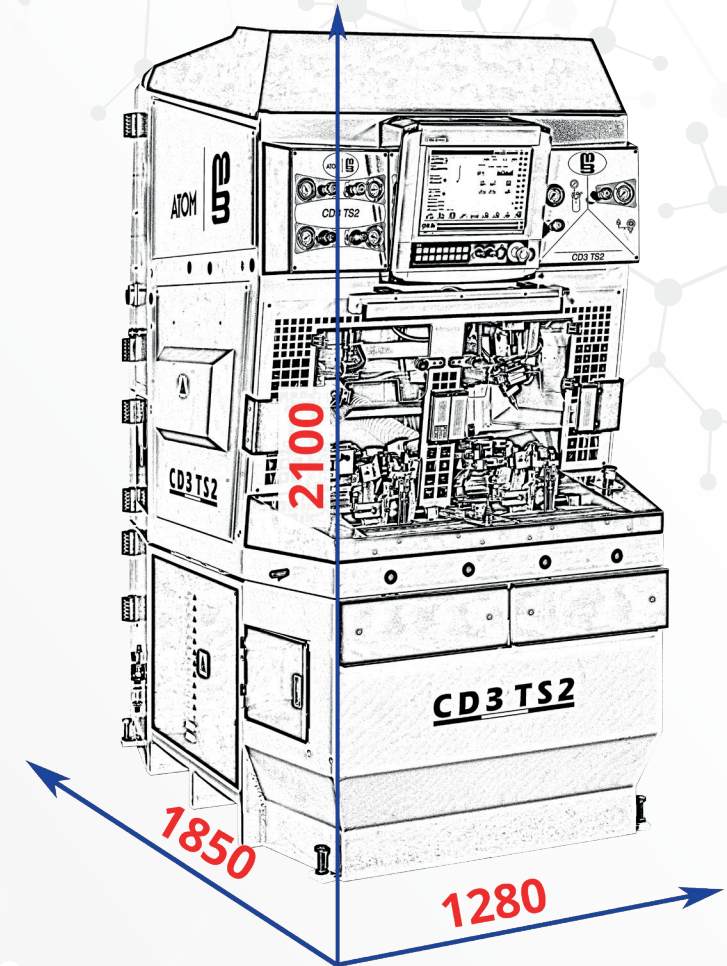



avantium
A CERIM AND ATOM COMPANY

Avantium

Corso Novara, 218
27029 Vigevano (PV) - Italia
Tel: +39 0381 20905
www.avantium.it
Email: info@avantium.it



ATOM



MADE IN ITALY