



avantium

A CERIM AND ATOM COMPANY

Shoes machinery  
and automated systems



ATOM



MADE IN ITALY

# CD10 TS2/SC

## Macchina per sgrossare/cardare il fondo della scarpa



Con 2 teste indipendenti che lavorano contemporaneamente.  
Alternativamente entrambe le teste possono essere configurate come sgrossa/sgrossa o carda/carda per situazioni di elevata produzione.

- Monitor touch screen da 15", in posizione ergonomica
- Sistema operativo MS Windows
- Sistema di salvataggio e aggiornamento dei dati con supporto USB
- Reale possibilità di assistenza remota
- Programmazione dell'utensile di sgrossatura/cardatura che segue il percorso tridimensionale
- Velocità e pressione degli utensili programmabile punto a punto
- Fotocellule per sbloccare la forma, senza intervento manuale
- Autoapprendimento del profilo della scarpa con sviluppo automatico della numerata
- Insonorizzazione
- Assistenza remota mediante TeamViewer
- Conforme ai requisiti Industria 4.0

### SETTORI DI APPLICAZIONE



Uomo



Donna



Bambino



Safety



Sportive



Sneakers Montato



Goodyear

# CARATTERISTICHE CD10 TS2/SC



## AUTOAPPRENDIMENTO

Autoapprendimento del profilo della calzatura e calcolo automatico dell'inclinazione degli utensili, il tutto comodamente gestito tramite schermo touch screen.



## SGROSSATURA E CARDATURA

La sgrossatura avviene tramite una fresa o spazzola che elimina le eccedenze del montaggio, a garanzia di una efficace cardatura..



## IMPOSTAZIONI ERGONOMICHE

Touch screen in posizione ergonomica. Sistema operativo evoluto in windows, comunicazione universale; sistemi di salvataggio dati e aggiornamenti tramite supporto usb.

## OPTIONAL E ACCESSORI

- Smerigliatrice laterale

[VAI ALLA SCHEDA TECNICA >](#)

# CD10 TS2/SC

## Rough-milling/roughing machine for the bottom of the shoe



With two independent heads that carry out the operations simultaneously. Alternately, both the heads can be set as rough-milling/rough-milling or roughing/roughing for high productivity working.

It presents the following features:

- 15" Touch Screen monitor, in ergonomic position
- MS Windows operative system
- Data saving and updating system by means of USB support
- Real possibility of remote assistance
- Rough-milling/roughing tool adjustment following the three-dimensional path
- Speed and pressure of the tools adjustable point by point
- Photocells to unlock the last, without manual intervention
- Self-learning of the footwear profile with automatic shoe size development
- Soundproofing
- Remote assistance by TeamViewer
- Industria 4.0 ready

### SECTORS OF APPLICATION



Man



Woman



Child



Safety



Sports



Lasted Sneakers



Goodyear

# FEATURES CD10 TS2/SC



## SELF-LEARNING

Self-learning of the shoe profile by pen, and automatic calculation of the inclination of the tools, all conveniently managed by touchscreen.



## ROUGH MILLING / ROUGHING

The rough milling is carried out by a grinding roller which eliminates lasting excess materials, effective roughing.



## ERGONOMIC SETTINGS

Touch screen in ergonomic position. Windows updated operating system, universal communication; data rescue system and updates by USB support.

## OPTIONALS & ACCESSORIES

- Roughing tool on the machine side

[VIEW DATASHEET >](#)

# SCHEMA TECNICA CD10 TS2/SC

DIMENSIONI (L x P x H)	mm 1330 x 2060 x 2260
DIMENSIONI IMBALLO	mm 1450 x 2200 x 2240
PESO NETTO	kg 1400
PESO LORDO IN CASSA	kg 1700
POTENZA ELETTRICA TOTALE INSTALLATA	Kw 12,0
ALIMENTAZIONE PNEUMATICA	Bar 6
ALIMENTAZIONE ELETTRICA	3PH + PE

< TORNA AI DETTAGLI DELLA MACCHINA

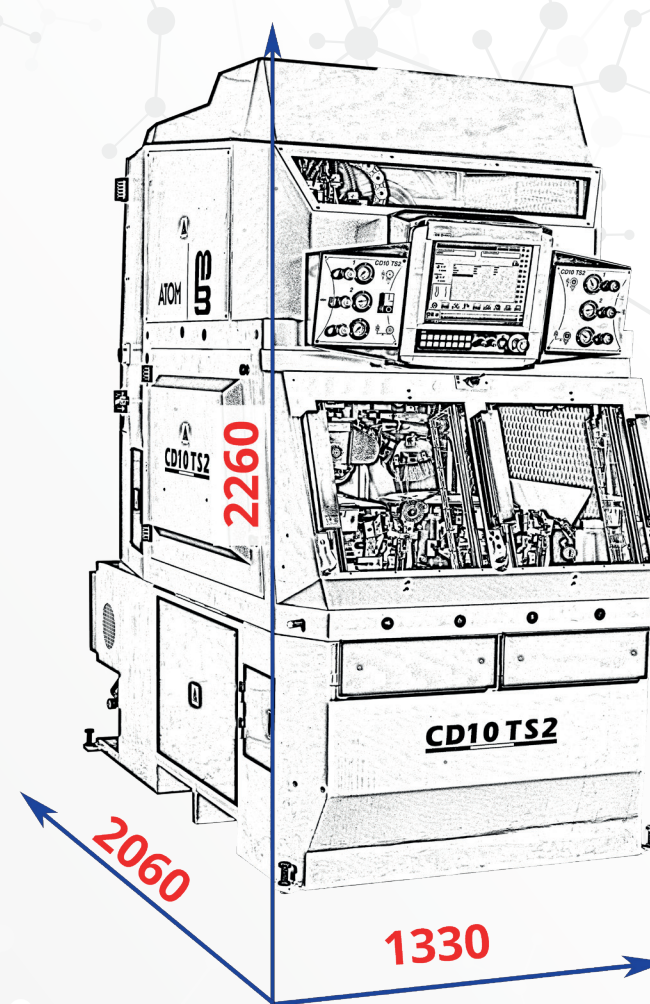

# TECHNICAL FEATURES CD10 TS2/SC

DIMENSIONS (L x W x H)	mm 1330 x 2060 x 2260
PACKAGING DIMENSIONS	mm 1450 x 2200 x 2240
NET WEIGHT	kg 1400
GROSS WEIGHT IN CASE	kg 1700
TOTAL INSTALLED ELECTRIC POWER	Kw 12,0
PNEUMATIC POWER SUPPLY	Bar 6
POWER SUPPLY	3PH + PE

[< BACK TO THE MACHINE DETAILS](#)

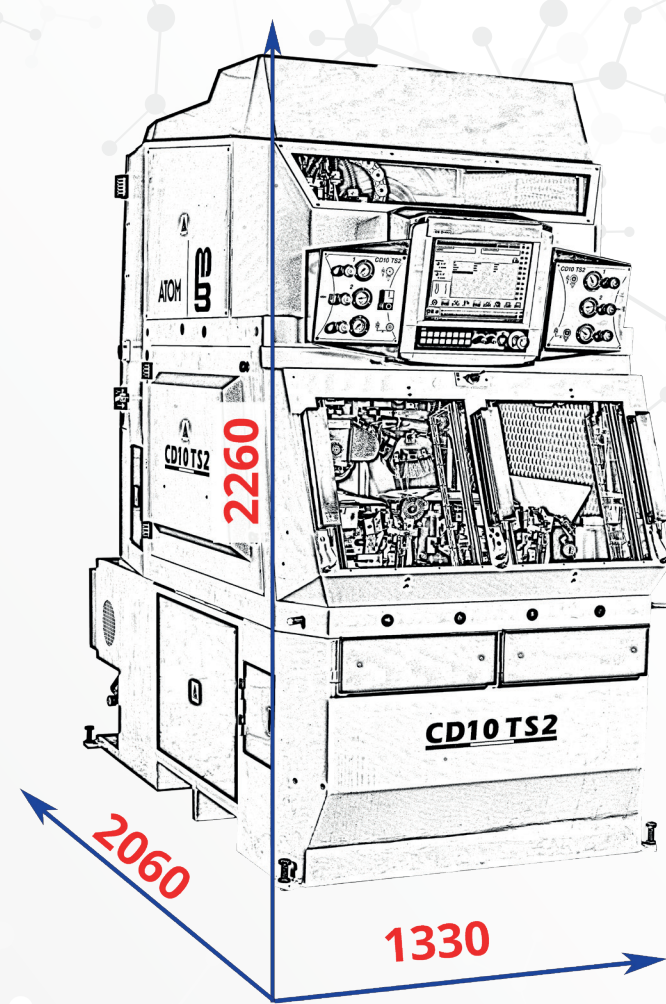



avantium

A CERIM AND ATOM COMPANY

**Avantium**

Corso Novara, 218

27029 Vigevano (PV) - Italia

Tel: +39 0381 20905

[www.avantium.it](http://www.avantium.it)

Email: [info@avantium.it](mailto:info@avantium.it)



ATOM



MADE IN ITALY